



**ZANOTTI Spa**  
Via M.L. King, 30  
46020 - Pegognaga (MN) - ITALY  
Tel. +39 0376 5551  
Fax +39 0376 536554  
info@zanotti.com

## Technical specifications

Version 1.48

Model:

Class:

**BGM117DA11XA**

**Uniblock GM**

### Technical data

Characteristics	M.U.	Value
Working temperature	°C	-15 ÷ -25
Starting mode		Direct
Voltage	Volt-Ph-Hz	230/1/50
Rated input	kW*	0,90
Rated input	Amp*	5,60
Peak current	Amp	42,0
Max current	Amp	10,9
Refrigerant		R452A
	GWP	2140
Defrost		Hot gas
Mass	Kg	64



### Compressor

Type		Hermetic
Nominal power	kW	1,3

### Condenser

Air flow	m³/h	600
----------	------	-----

### Evaporator

Air flow	m³/h	600
Air throw	m**	4

PED Category		0
--------------	--	---

### Power data

Tc °C	Ta °C	P watt	P Kcal/h	V120 m³	V100 m³	V80 m³
-15	20	1513	1301	13	12	10
	25	1429	1229	12	11	9,4
	30	1341	1153	10	8,9	7,8
	35	1251	1076	9,2	8,2	7,2
	40	1158	996	8,1	7,2	6,3
-20	45	1066	917	7,1	6,3	5,5
	20	1297	1115	9,8	8,7	7,6
	25	1224	1053	8,9	7,9	6,9
	30	1155	993	8,1	7,2	6,3
	35	1081	930	7,2	6,4	5,6
-25	40	993	854	6,3	5,6	4,9
	45	881	758	5,1	4,5	4
	20	1090	937	7,3	6,5	5,7
	25	1016	874	6,5	5,8	5,1
	30	943	811	5,7	5,1	4,4
-25	35	871	749	5	4,4	3,9
	40	798	686	4,3	3,8	3,4
	45	725	624	3,6	3,2	2,8

\* When normally running: -20 ÷ +30°C

\*\* Use air throw as a base. Air throw is affected by many factors such as height of room, product storage, location of evaporator, etc.

Tc: Coldroom temp. - Ta: External temp.

P: Refrigerant capacity - V: Recommended cold-room volume

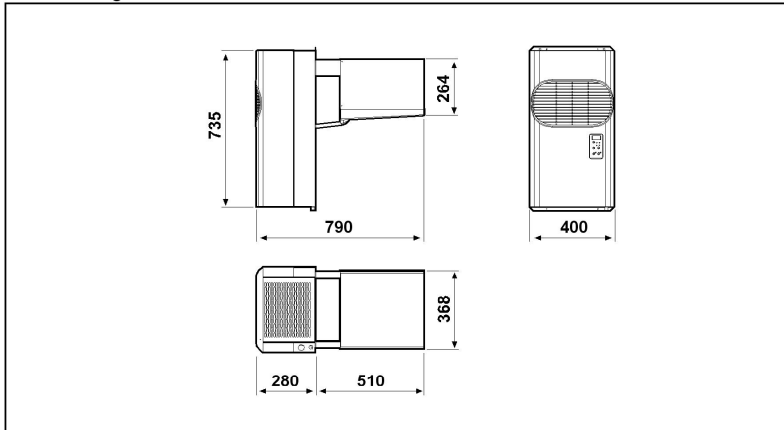

Schema di montaggio - Mounting scheme - Schema de montage  
Montageschema - Esquema de montaje

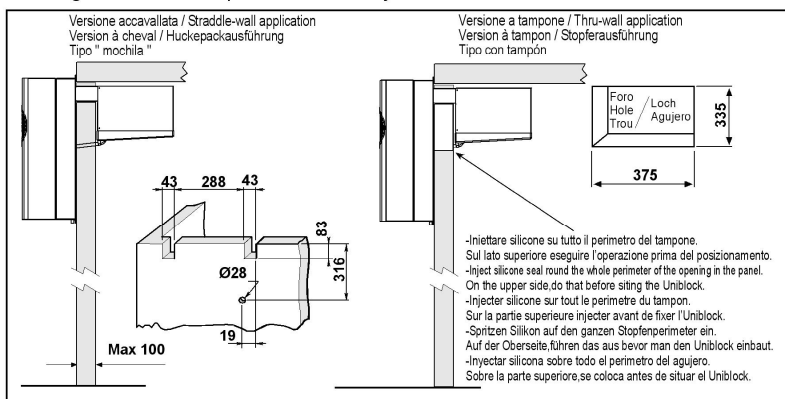

- \* Raccomandazioni in sede di installazione e per il controllo fornite sul manuale di installazione
- \* To be advised at time of order for factory installation and operating instructions
- \* Recommendations au moments d'installations et pour le contrôle fournis sur le manuel d'installation
- \* Empfehlungen für die Installationsphase und zur Kontrolle, die im Handbuch zur Installation enthalten sind
- \* Por cuanto respecta a recomendaciones de instalación y control ver manual de instalación

Massa e misure imballi - Packing mass and dimensions - Masse et dimensions emballages  
Verpackungsmasse und-abmessungen - Masa y medidas del embalaje

