



ZANOTTI Spa
Via M.L. King, 30
46020 - Pegognaga (MN) - ITALY
Tel. +39 0376 5551
Fax +39 0376 536554
info@zanotti.com

Technical specifications

Version 1.48

Model:

Class:

MGM105EA11XA

Uniblock GM

Technical data

Characteristics	M.U.	Value
Working temperature	°C	+10 + -5
Starting mode		Direct
Voltage	Volt-Ph-Hz	230/1~/50
Rated input	kW*	0,80
Rated input	Amp*	4,90
Peak current	Amp	26,0
Max current	Amp	8,1
Refrigerant		R134a
	GWP	1430
Defrost		Hot gas
Mass	Kg	53

Compressor

Type	Hermetic	
Nominal power	kW	0,4

Condenser

Air flow	m³/h	600
----------	------	-----

Evaporator

Air flow	m³/h	600
Air throw	m**	4

PED Category		0
--------------	--	---



Power data

Tc °C	Ta °C	P watt	P Kcal/h	V100 m³	V80 m³	V60 m³
	20	1564	1345	14	13	12
	25	1481	1274	13	12	11
10	30	1384	1190	12	11	10
	35	1280	1101	11	10	9,1
	40	1172	1008	9,2	8,4	7,6
	45	1067	918	8,1	7,4	6,7
	20	1365	1174	12	11	10
	25	1256	1080	10	9,1	8,3
5	30	1173	1009	9,3	8,5	7,7
	35	1103	949	8,5	7,7	7,1
	40	1031	887	7,7	7	6,4
	45	946	814	6,8	6,2	5,6
	20	1157	995	9,1	8,3	7,6
	25	1055	907	7,9	7,2	6,6
0	30	978	841	7,1	6,5	5,9
	35	914	786	6,4	5,8	5,3
	40	850	731	5,8	5,3	4,8
	45	772	664	5	4,6	4,1
	20	974	838	7,1	6,5	5,9
	25	880	757	6,1	5,6	5,1
-5	30	811	697	5,4	4,9	4,5
	35	753	648	4,8	4,4	4
	40	695	598	4,3	3,9	3,6
	45	626	538	3,7	3,4	3,1

* When normally running: 0 + +30°C

** Use air throw as a base. Air throw is affected by many factors such as height of room, product storage, location of evaporator, etc.

Tc: Coldroom temp. - Ta: External temp.

P: Refrigerant capacity - V: Recommended cold-room volume

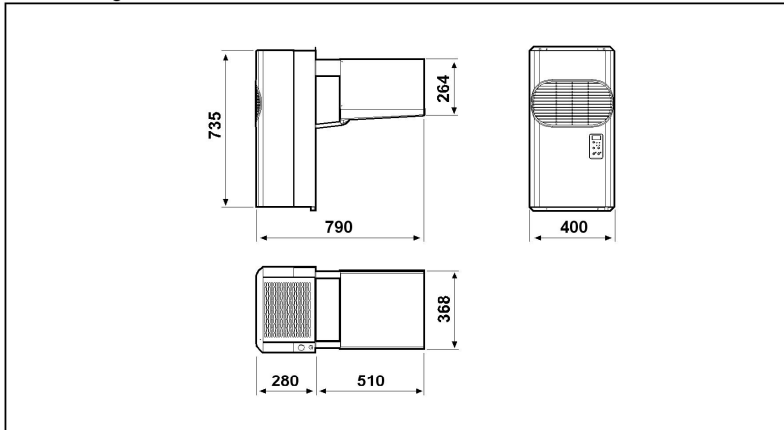

Schema di montaggio - Mounting scheme - Schema de montage
Montageschema - Esquema de montaje

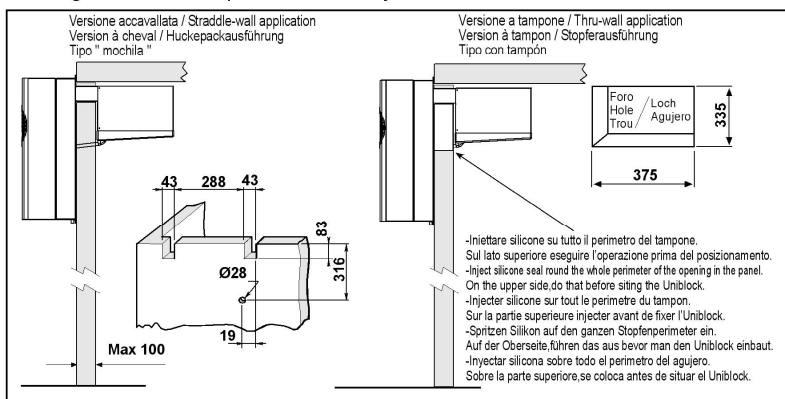

- * Raccomandazioni in sede di installazione e per il controllo fornite sul manuale di installazione
- * To be advised at time of order for factory installation and operating instructions
- * Recommendations au moments d'installations et pour le contrôle fournis sur le manuel d'installation
- * Empfehlungen für die Installationsphase und zur Kontrolle, die im Handbuch zur Installation enthalten sind
- * Por cuanto respecta a recomendaciones de instalación y control ver manual de instalación

Massa e misure imballi - Packing mass and dimensions - Masse et dimensions emballages
Verpackungsmasse und-abmessungen - Masa y medidas del embalaje

