



ZANOTTI Spa
Via M.L. King, 30
46020 - Pegognaga (MN) - ITALY
Tel. +39 0376 5551
Fax +39 0376 536554
info@zanotti.com

Technical specifications

Version 1.48

Model:

Class:

MGM106EA11XA

Uniblock GM

Technical data

Characteristics	M.U.	Value
Working temperature	°C	+10 + -5
Starting mode		Direct
Voltage	Volt-Ph-Hz	230/1~/50
Rated input	kW*	1,00
Rated input	Amp*	6,10
Peak current	Amp	31,0
Max current	Amp	9,2
Refrigerant		R134a
	GWP	1430
Defrost		Hot gas
Mass	Kg	56



Compressor

Type		Hermetic
Nominal power	kW	0,5

Condenser

Air flow	m³/h	600
----------	------	-----

Evaporator

Air flow	m³/h	600
Air throw	m**	4

PED Category		0
--------------	--	---

Power data

Tc °C	Ta °C	P watt	P Kcal/h	V100 m³	V80 m³	V60 m³
	20	1786	1536	17	15	14
	25	1671	1437	15	14	12
10	30	1568	1348	14	13	12
	35	1466	1261	13	12	11
	40	1355	1165	11	10	9,1
	45	1226	1054	9,9	9	8,2
	20	1534	1319	14	13	12
	25	1416	1218	12	11	10
5	30	1324	1139	11	10	9,1
	35	1248	1073	10	9,1	8,3
	40	1173	1009	9,3	8,5	7,7
	45	1089	937	8,3	7,6	6,9
	20	1313	1129	11	10	9,1
	25	1205	1036	9,6	8,7	8
0	30	1120	963	8,7	7,9	7,2
	35	1047	900	7,9	7,2	6,6
	40	977	840	7,1	6,5	5,9
	45	900	774	6,3	5,7	5,2
	20	1117	961	8,6	7,8	7,1
	25	1001	861	7,4	6,7	6,1
-5	30	929	799	6,6	6	5,5
	35	874	752	6	5,5	5
	40	811	697	5,4	4,9	4,5
	45	715	615	4,5	4,1	3,7

* When normally running: 0 + +30°C

** Use air throw as a base. Air throw is affected by many factors such as height of room, product storage, location of evaporator, etc.

Tc: Coldroom temp. - Ta: External temp.

P: Refrigerant capacity - V: Recommended cold-room volume

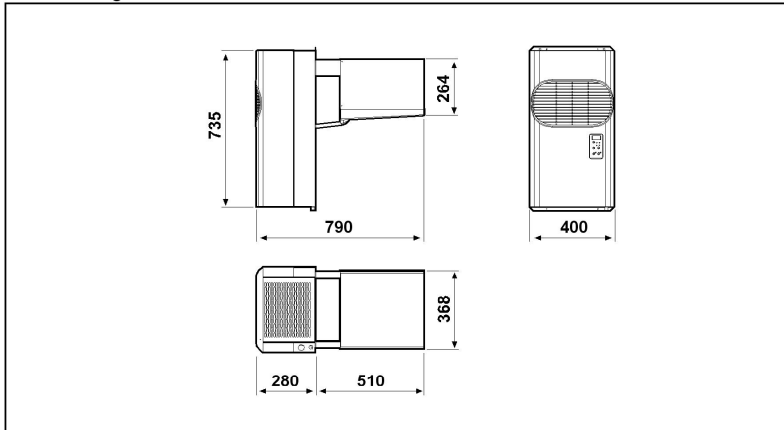

Schema di montaggio - Mounting scheme - Schema de montage
Montageschema - Esquema de montaje

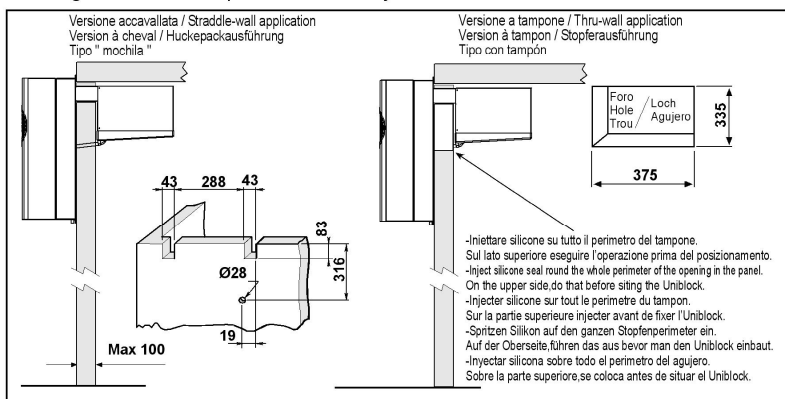

- * Raccomandazioni in sede di installazione e per il controllo fornite sul manuale di installazione
- * To be advised at time of order for factory installation and operating instructions
- * Recommendations au moments d'installations et pour le contrôle fournis sur le manuel d'installation
- * Empfehlungen für die Installationsphase und zur Kontrolle, die im Handbuch zur Installation enthalten sind
- * Por cuanto respecta a recomendaciones de instalación y control ver manual de instalación

Massa e misure imballi - Packing mass and dimensions - Masse et dimensions emballages
Verpackungsmasse und-abmessungen - Masa y medidas del embalaje

